



Energy Division

## Insulated insulation piercing connectors for mains-service connections

MSIP connectors allow 'live' jointing of service conductors onto various low voltage mains cable types. These includes stranded or solid, 120° and 90° sectorial or round mains conductors up to the maximum cross section and stranded or solid service conductors up to 35mm<sup>2</sup>.

Two entry ports are provided for service cables thus allowing for two service connections per connector. Maximum total size of the two service conductors depends on the mains cable size (e.g. MSIP300 is suitable for 2 x 25mm<sup>2</sup> stranded copper services, 2 x 35mm<sup>2</sup> solid aluminium services, or 1 x 35mm<sup>2</sup> stranded copper service). Service connections are made with a 3mm grub screw.

- A holding tool is available for fixing the connector during installation  
PN BAH-018050012 (TCPN 549674-000)
- An insulated 3mm Allen key (Boddingtons PN 117303S) is recommended for making service connections.

### Features

- Installed using insulated insulation piercing bolts with 19mm A/F hexagon drive head
- Connector body fully shrouded - no exposed metalwork during installation
- Insulated drive mechanism detaches when installation is complete to reduce connector size
- One connector for all cable types

### Standards

- Tested to IEC 61238-1

DATA SHEET Number: EPP-1738	Date: 01/11/2009 Revision: A
--------------------------------	---------------------------------

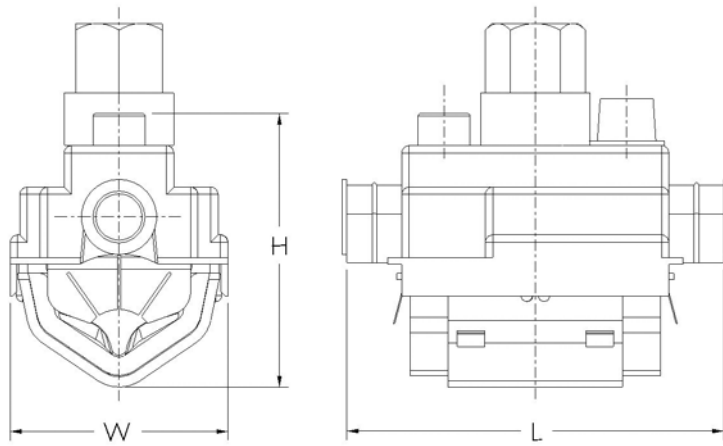

Reference	PN	TCPN	Dimensions (mm)			Conductor size (mm <sup>2</sup> )
			L	H	W	
MSIP185	BAH-O21500003	230062-000	83	60	48	50-185
MSIP300	BAH-O21500011	580454-000	83	68	55	185-300

While Tyco Electronics and its affiliates referenced herein have made every reasonable effort to ensure the accuracy of the information contained in this catalogue, Tyco Electronics cannot assure that this information is error free. For this reason, Tyco Electronics does not make any representation or offer any guarantee that such information is accurate, correct, reliable or current. Tyco Electronics reserves the right to make any adjustments to the information at any time. Tyco Electronics expressly disclaims any implied warranty regarding the information contained herein, including, but not limited to, the implied warranties of merchantability or fitness for a particular purpose. Tyco Electronics' only obligations are those stated in Tyco Electronics' Standard Terms and Conditions of Sale. Tyco Electronics will in no case be liable for any incidental, indirect or consequential damages arising from or in connection with, including, but not limited to, the sale, resale, use or misuse of its products. Users should rely on their own judgement to evaluate the suitability of a product for a certain purpose and test each product for its intended application. TE (logo) and Tyco Electronics are trademarks of the Tyco Electronics group of companies and its licensors.

**Energy Division - economical solutions for the electrical power industry: cable accessories, connectors & fittings, electrical equipment, instruments, lighting controls, insulators & insulation enhancement and surge arresters.**

**Tyco Electronics UK Ltd**

Energy Division  
 Freebournes Road  
 Witham, Essex CM8 3AH

Phone: +44 (0)870 870 7500  
 Fax: +44 (0)870 240 5289  
 Email: [ukutilities@tycoelectronics.com](mailto:ukutilities@tycoelectronics.com)

<http://energy.tycoelectronics.com>



Our commitment. Your advantage.

DATA SHEET  
 Number: EPP-1738  
 Date: 01/11/2009  
 Revision: A