





CR1

A mm ø	B inches ø	C mm ²				MINI 	MINI 
12.7	½"	16*	65P10	CR1-4-12716	HCPK4	CR1-3-12716	HCPK3
12.7	½"	25	65P10	CR1-4-12725	HCPK4	CR1-3-12725	HCPK3
12.7	½"	35	65P10	CR1-4-12735	HCPK4	CR1-3-12735	HCPK3
12.7	½"	50	65P10	CR1-4-12750	HCPK4	CR1-3-12750	HCPK3
12.7	½"	8mm Ø	65P10	CR1-4-1278SC	HCPK4	CR1-3-1278SC	HCPK3
12.7	½"	70	90P10	CR1-4-12770	HCPK4	CR1-3-12770	HCPK3
12.7	½"	95	90P10	CR1-4-12795	HCPK4	CR1-3-12795	HCPK3
12.7	½"	120	90P10	CR1-4-127120	HCPK4	CR1-3-127120	HCPK3
14.2	⅝"	16*	65P10	CR1-4-14216	HCPK4	CR1-3-14216	HCPK3
14.2	⅝"	25	65P10	CR1-4-14225	HCPK4	CR1-3-14225	HCPK3
14.2	⅝"	35	65P10	CR1-4-14235	HCPK4	CR1-3-14235	HCPK3
14.2	⅝"	50	90P10	CR1-4-14250	HCPK4	CR1-3-14250	HCPK3
14.2	⅝"	8mm Ø	90P10	CR1-4-1428SC	HCPK4	CR1-3-1428SC	HCPK3
14.2	⅝"	70	90P10	CR1-4-14270	HCPK4	CR1-3-14270	HCPK3
14.2	⅝"	95	90P10	CR1-4-14295	HCPK4	CR1-3-14295	HCPK3
14.2	⅝"	120	90P10	CR1-4-142120	HCPK4	CR1-3-142120	HCPK3
14.2	⅝"	150	115P10	CR1-4-142150	HCPK4	CR1-3-142150	HCPK3
14.2	⅝"	185	115P10	CR1-4-142185	HCPK4	CR1-3-142185	HCKP3
14.2	⅝"	240	150P10	CR1-4-142240	HCPK4	-	-
17.2	¾"	16*	65P10	CR1-4-17216	HCPK4	CR1-3-17216	HCPK3
17.2	¾"	25	65P10	CR1-4-17225	HCPK4	CR1-3-17225	HCPK3
17.2	¾"	35	65P10	CR1-4-17235	HCPK4	CR1-3-17235	HCPK3
17.2	¾"	50	90P10	CR1-4-17250	HCPK4	CR1-3-17250	HCPK3
17.2	¾"	8mm Ø	90P10	CR1-4-1728SC	HCPK4	CR1-3-1728SC	HCPK3
17.2	¾"	70	90P10	CR1-4-17270	HCPK4	CR1-3-17270	HCPK3
17.2	¾"	95	90P10	CR1-4-17295	HCPK4	CR1-3-17295	HCPK3
17.2	¾"	120	90P10	CR1-4-172120	HCPK4	CR1-3-172120	HCPK3
17.2	¾"	150	115P10	CR1-4-172150	HCPK4	CR1-3-172150	HCPK3
17.2	¾"	185	115P10	CR1-4-172185	HCPK4	CR1-3-172185	HCPK3
17.2	¾"	240	150P10	CR1-4-172240	HCPK4	-	-
17.2	¾"	300	200P10	CR1-4-172300	HCPK4	-	-



Suitable for connections to copperbond rods – for connections to solid copper and stainless steel rods please contact our sales office.

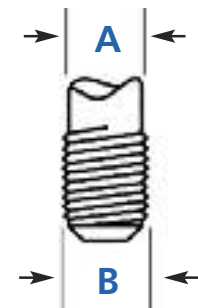
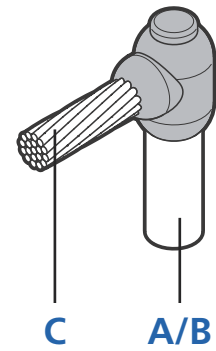

Threaded portion of copperbond rods must be removed prior to welding.

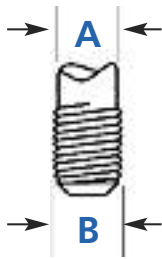
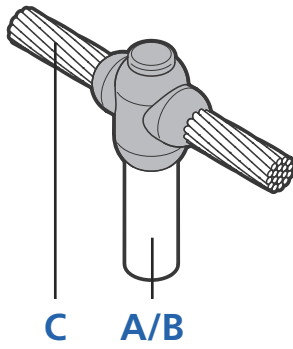

CR2

A mm ø	B inches ø	C mm ²					
12.7	½"	16*	90P10	CR2-4-12716	HCPK4	CR2-3-12716	HCPK3
12.7	½"	25	90P10	CR2-4-12725	HCPK4	CR2-3-12725	HCPK3
12.7	½"	35	90P10	CR2-4-12735	HCPK4	CR2-3-12735	HCPK3
12.7	½"	50	90P10	CR2-4-12750	HCPK4	CR2-3-12750	HCPK3
12.7	½"	8mm Ø	90P10	CR2-4-1278SC	HCPK4	CR2-3-1278SC	HCPK3
12.7	½"	70	90P10	CR2-4-12770	HCPK4	CR2-3-12770	HCPK3
12.7	½"	95	115P10	CR2-4-12795	HCPK4	CR2-3-12795	HCPK3
12.7	½"	120	150P10	CR2-4-127120	HCPK4	-	-
14.2	⅝"	16*	90P10	CR2-4-14216	HCPK4	CR2-3-14216	HCPK3
14.2	⅝"	25	90P10	CR2-4-14225	HCPK4	CR2-3-14225	HCPK3
14.2	⅝"	35	90P10	CR2-4-14235	HCPK4	CR2-3-14235	HCPK3
14.2	⅝"	50	90P10	CR2-4-14250	HCPK4	CR2-3-14250	HCPK3
14.2	⅝"	8mm Ø	90P10	CR2-4-1428SC	HCPK4	CR2-3-1428SC	HCPK3
14.2	⅝"	70	115P10	CR2-4-14270	HCPK4	CR2-3-14270	HCPK3
14.2	⅝"	95	115P10	CR2-4-14295	HCPK4	CR2-3-14295	HCPK3
14.2	⅝"	120	150P10	CR2-4-142120	HCPK4	-	-
14.2	⅝"	150	200P10	CR2-4-142150	HCPK4	-	-
14.2	⅝"	185	200P10	CR2-4-142185	HCPK4	-	-
14.2	⅝"	240	250P10	CR2-4-142240	HCPK4	-	-
17.2	¾"	16*	90P10	CR2-4-17216	HCPK4	CR2-3-17216	HCPK3
17.2	¾"	25	90P10	CR2-4-17225	HCPK4	CR2-3-17225	HCPK3
17.2	¾"	35	90P10	CR2-4-17235	HCPK4	CR2-3-17235	HCPK3
17.2	¾"	50	115P10	CR2-4-17250	HCPK4	CR2-3-17250	HCPK3
17.2	¾"	8mm Ø	115P10	CR2-4-1728SC	HCPK4	CR2-3-1728SC	HCPK3
17.2	¾"	70	115P10	CR2-4-17270	HCPK4	CR2-3-17270	HCPK3
17.2	¾"	95	115P10	CR2-4-17295	HCPK4	CR2-3-17295	HCPK3
17.2	¾"	120	150P10	CR2-4-172120	HCPK4	-	-
17.2	¾"	150	200P10	CR2-4-172150	HCPK4	-	-
17.2	¾"	185	200P10	CR2-4-172185	HCPK4	-	-
17.2	¾"	240	250P10	CR2-4-172240	HCPK4	-	-
17.2	¾"	300	2 x 150P10	CR2-5-172300	HCPK5	-	-

Suitable for connections to copperbond rods –
for connections to solid copper and stainless steel rods
please contact our sales office.



Threaded portion of copperbond rods must be removed
prior to welding.

CR3

A mm Ø	B inches Ø	C mm ²			
12.7	½"	16*	90P10	CR3-9-12716	HCPK4
12.7	½"	25	90P10	CR3-9-12725	HCPK4
12.7	½"	35	90P10	CR3-9-12735	HCPK4
12.7	½"	50	115P10	CR3-9-12750	HCPK4
12.7	½"	8mm Ø	115P10	CR3-9-1278SC	HCPK4
12.7	½"	70	115P10	CR3-9-12770	HCPK4
12.7	½"	95	115P10	CR3-9-12795	HCPK4
12.7	½"	120	150P10	CR3-9-127120	HCPK4
14.2	⅝"	16*	90P10	CR3-9-14216	HCPK4
14.2	⅝"	25	90P10	CR3-9-14225	HCPK4
14.2	⅝"	35	90P10	CR3-9-14235	HCPK4
14.2	⅝"	50	115P10	CR3-9-14250	HCPK4
14.2	⅝"	8mm Ø	115P10	CR3-9-1428SC	HCPK4
14.2	⅝"	70	115P10	CR3-9-14270	HCPK4
14.2	⅝"	95	115P10	CR3-9-14295	HCPK4
14.2	⅝"	120	150P10	CR3-9-142120	HCPK4
14.2	⅝"	150	150P10	CR3-9-142150	HCPK4
14.2	⅝"	185	200P10	CR3-9-142185	HCPK4
14.2	⅝"	240	2 x 200P10	CR3-10-142240	HCPK5
17.2	¾"	16*	90P10	CR3-9-17216	HCPK4
17.2	¾"	25	90P10	CR3-9-17225	HCPK4
17.2	¾"	35	90P10	CR3-9-17235	HCPK4
17.2	¾"	50	115P10	CR3-9-17250	HCPK4
17.2	¾"	8mm Ø	115P10	CR3-9-1728SC	HCPK4
17.2	¾"	70	150P10	CR3-9-17270	HCPK4
17.2	¾"	95	150P10	CR3-9-17295	HCPK4
17.2	¾"	120	200P10	CR3-9-172120	HCPK4
17.2	¾"	150	250P10	CR3-9-172150	HCPK4
17.2	¾"	185	2 x 200P10	CR3-10-172185	HCPK5
17.2	¾"	240	2 x 250P10	CR3-10-172240	HCPK5
17.2	¾"	300	3 x 200P10	CR3-10-172300	HCPK5

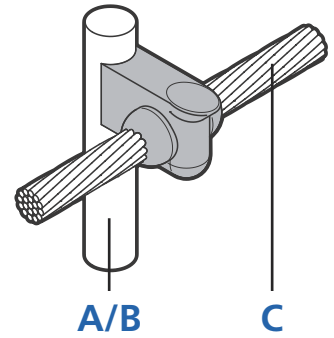

Suitable for connections to copperbond rods –
for connections to solid copper and stainless steel rods
please contact our sales office.



Threaded portion of copperbond rods must be removed
prior to welding.

Frames

The CR3 joint type utilises a 3 part mould. For this reason, a Frame is required in
addition to the standard Handle Clamp.

Description	Part No.
Frame for use with Handle Clamp HCPK4	F1-FU
Frame for use with Handle Clamp HCPK5	F2-FU